

## Operating Instructions 007e

# LABOPORT<sup>®</sup> Mini Laboratory Pumps

Type ranges N 86 KN.18  
N 86 KT.18

N 811 KN.18  
N 811 KT.18

N 816.1.2 KN.18  
N 816.1.2 KT.18  
N 816.3 KN.18  
N 816.3 KT.18



Fig. 1  
N 86 KN.18



Fig. 2  
N 811 KN.18



Fig. 3  
N 816.1.2 KN.18

You have selected a high-quality KNF product; the following tips will help you operate it safely, and reliably over a long period of time. **Carefully study the operating instructions before using the pumps and observe at all times the relevant instructions to avoid dangerous situations.** The manual was produced for the serial pumps stated above. Within customer-specified projects (pump types starting with "PJ" or "PM") there could be differences in detail. For customer-specified projects please therefore take into account any agreed technical specifications, as well as these instructions.

### 0. List of Contents

1. Description, Operating Conditions
2. Safety
3. Installation
4. Operation
5. Servicing
6. Trouble Shooting
7. Spare Parts
8. Specifications
9. Accessories
10. Tables

## 1. Description, Operating Conditions

KNF pumps in the range N 86 K\_18, N 811K\_18, and N 816\_K\_18 transfer, evacuate and compress 100 % oil-free. In operation they are gas-tight, and maintenance-free.

### 1.1 Electrical Equipment

- See table 1 for full electrical data.
- The protection class of standard versions is IP 20.
- The pumps are fitted with a thermal switch to protect against overloading.

### 1.2 Operating Conditions

- Handling air, gases, and vapours at temperatures between + 5 °C... + 40 °C.
- For maximum permissible operating pressure, ultimate vacuum, and flow capacity: see table 2.
- ⚠ The pumps must not be used in areas where there is a danger of explosion.
- The pumps must not be used for liquids. You will find suitable liquid pumps in our Product Program.
- For vacuum pumps: The gas discharge at the pressure side must be drained off safely and reliably.
- Before pumping a medium, the compatibility of materials of pump head, diaphragm and valves with the medium must be checked (for pump materials: see table 3).
- Pumps that may be employed as vacuum pump and compressor must not be used to produce vacuum and pressure at the same time.

If your potential application lies outside the above limits discuss it with our technical adviser (see last page for contact telephone number).

### 1.3 Ambient Condition

When the pumps are operating the following ambient conditions must be maintained:

- Ambient temperature during operation: between + 5 °C .... + 40 °C.
- During operation an adequate supply of air for cooling must be provided.
- The pumps must not be used in areas where there is a danger of explosion.

### 1.4 Pump materials

See table 3.

## 2. Safety

- Note that the pumps may only be

used for their intended purpose.

- ⚠ The pumps must not be used in areas where there is a danger of explosion.
- For vacuum pumps: The gas discharge at the pressure side must be drained off safely and reliably.
- ⚠ Components connected to the pumps must be designed to withstand the pneumatic performance of the pumps (see table 2).
- Plug the pump only into properly installed grounded outlets.
- ⚠ When the operation of the pump is interrupted by the thermal switch, the pump will re-start automatically after cooling down. Take all care necessary to prevent this leading to a dangerous situation.
- ⚠ Specific safety instructions and measures for the media being handled must be observed.
- Use only original KNF spare parts.
- ▶ The pumps conform to the safety regulations of the EC Low Voltage Directive 73/23 EEC, and of the EC Directive 89/336 EEC concerning Electromagnetic Compatibility. The requirements of the following harmonized standards are fulfilled: EN 61010 part 1, EN 50081 part 1, EN 50082 part 1.

## 3. Installation

- Choose a safe location (flat surface) for the pump.
- Install the pump so as to ensure adequate flow of air cooling.
- Fit the pump at the highest point in the system, so that condensate cannot collect in the head of the pump - that prolongs working life of structured diaphragm and pump.
- At the pump head (for double-head pumps: at the pump heads), remove the protection plugs from the hose connectors.
- Mounting the accessory parts filter or silencer (if present): If the pump is used as a vacuum pump, mount a silencer at the pressure side if necessary. If the pump is used as a compressor (not permitted with series N 816\_K\_18), mount a filter at the suction side if necessary.
  - ▶ Before mounting the filter or silencer, unscrew the corresponding hose connector from the threads in the pump head.
- Connect the suction and pressure lines (N 86 K\_18: tube ID 4 mm, N 811 K\_18 and N 816\_K\_18: ID 6 mm). For flow direction see marking on the pump head.
- Arrange the suction and pressure lines so that condensate cannot run into the pump (sloping lines).
- Plug the pump only into properly installed grounded outlets.
- Compare the supply data with the electrical data of the pump. The

voltage must not vary by more than + 10 % and -10 % from that shown on the type-plate.

## 4. Operation

- The pumps can be switched on and off using the power switch.
- ⚠ Specific safety instructions for the media being handled must be observed.
- Before pumping a medium, the compatibility of materials of pump head, diaphragm, and valves with the medium must be checked (for pump materials: see table 3).
- The pumps must not start against pressure or vacuum. This also applies when the pump restarts after the power has been cut off for a short period. If a pump starts under pressure or vacuum, then the thermal switch will be activated and switch the pump off.
- ⚠ When the operation of the pump is interrupted by the thermal switch, the pump will re-start automatically after cooling down. Take all care necessary to prevent this leading to a dangerous situation.
- ⚠ The maximum permissible operating pressure (see table 2) must not be exceeded. Exception: if the data sheets include values for intermittent operation, they may employed briefly.
- To prevent the maximum permissible operating pressure being exceeded, restriction or control of the air or gas flow should only be carried out in the suction line.
- If restriction or control of the air or gas flow is made on the pressure side ensure that the maximum permissible operating pressure is not exceeded. Excessive pressure (with all of the related hazards) can be prevented by placing a bypass line with a pressure-relief valve between the pressure and suction sides of the pump. For further information, contact our specialists (telephone number: see last page).
- When the pump is at a standstill the inlet and exhaust must be at normal atmospheric pressure.
- Change the filter (accessory) if it is dirty.
- Pumps that may be employed as vacuum pump and compressor must not be used to produce vacuum and pressure at the same time.
- Diaphragm and valve plates are the only parts subject to wear. Wear is usually indicated by a drastic reduction in the pneumatic performance (vacuum, pressure, delivery). When replacing parts proceed as described in section 5.
- Ambient conditions: see chapter 1.3.

## 5. Servicing

**⚠ Before working on the pump, disconnect it from the electricity supply by pulling the plug out.**

- ▶ Diaphragm and valve plates are the only parts subject to wear. They are simple to change.
- ▶ Always change valve plates, diaphragm, and sealing rings at the same time. In the case of models with two pump heads service both heads at the same time. If the diaphragm is not changed in both heads at the same time or the diaphragm and the valve plates are not changed at the same time the nominal performance of the pump is not guaranteed after the service.
- ▶ If aggressive, toxic or other types of gases hazardous to health have been pumped please observe:
  - 1.) Clean the pump and its components before servicing.
  - 2.) Ensure that the service personnel is not subject to a health hazard during diaphragm and valve plate changes. Apply the necessary safety measures (example: the use of protective gloves).
  - 3.) Ensure that the discarded parts and materials are safely and correctly disposed of.

### 5.1.1 N 86 K\_18

#### Parts/tools required:

- Service Set (see section 8)
- Philips-head screwdriver No. 1
- Small screwdriver
- Pencil

Changing the structured diaphragm, valve plates, and sealing rings in the following sequence:

- a) Remove pump head
- b) Change structured diaphragm
- c) Change valve plates and sealing rings
- d) Refit pump head

See figs. 4 and 5.

#### a) Removing pump head

- 1 Mark the position of head plate ③, cover ⑤ and cover plate ⑥ relative to each other by a drawing line with a pencil. This helps avoid incorrect assembly later.
- 2 Undo the 4 screws ④ in the head plate and lift the head plate with the cover ⑤ off the pump housing.
- 3 Mark the position of intermediate plate ② and housing ① relative to each other by a drawing line with a pencil.
- 4 Lift the intermediate plate ② off the housing ①.

#### b) Change structured diaphragm

- 1 Using a small screwdriver, between the housing ① and the outer edge of the structured diaphragm ⑨, carefully lever the edge of the diaphragm lightly upwards.
- 2 Grip the structured diaphragm ⑨ on opposite sides, unscrew it about two turns (anti-clockwise).
- 3 Hold the pump with one hand, so that the head is pointing downwards. Turn the structured diaphragm ⑨ anti-clockwise to unscrew it.
- 4 Take the diaphragm support ⑩ and diaphragm spacer(s) ⑪ off the threaded portion of the diaphragm and retain them.
- 5 Check that all parts are free from dirt and clean them if necessary (see section 6. *Cleaning*).
- 6 Put the diaphragm support ⑩ and diaphragm spacer(s) ⑪, in that order, on the threaded portion of the new structured diaphragm ⑨.
- 7 Screw the new structured diaphragm ⑨, complete with diaphragm support ⑩ and diaphragm spacer(s) ⑪ into the connecting rod (clockwise) and tighten it by hand.

#### c) Changing the valve plates

- 1 Remove the valve plates ⑦ and sealing rings ⑧ from the intermediate plate ② (sealing rings could cling to the head plate).
- 2 Check that the valve seats in the head plate ③ and intermediate plate ② are clean. If scratches or distortion are evident on these parts they should be replaced.
- 3 Lay the new valve plates ⑦ in the recesses in the intermediate plate ②. The valve plates for suction and pressure sides are identical, as are upper and lower sides of the plates.
- 4 Check that the valve plates ⑦ are not deformed by moving them gently sideways in their recesses.
- 5 Lay the new sealing rings ⑧ on the intermediate plate ②.

#### d) Refitting the pump head

- 1 Place the intermediate plate ②, with valve plates ⑦ and sealing rings ⑧ on the housing ①, in the position indicated by the drawing line.
- 2 Place the head plate ③, with cover ⑤ on the housing ①, in the position indicated by the drawing line.
- 3 Check that the head plate ③ is centred by moving it gently sideways.
- 4 Tighten the screws ④, evenly and diagonally, first gently, then firmly.

- ▶ If you have any questions about servicing call our technical adviser (see last page for contact tele-

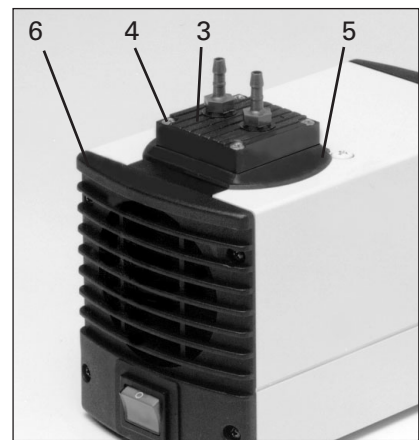

Fig. 4: N 86 K\_18

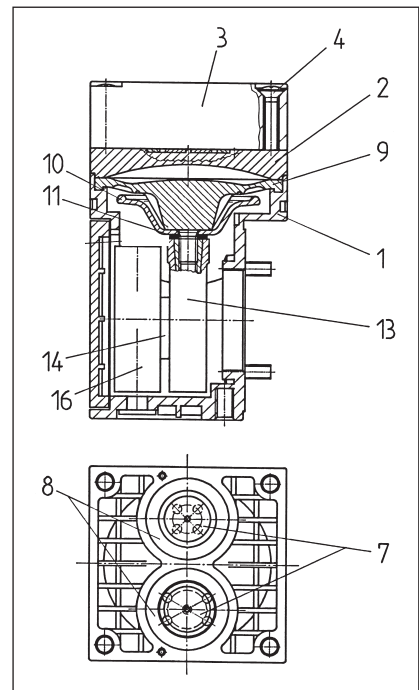

Fig. 5: N 86 K\_18

#### Specification

- ① Housing
- ② Intermediate plate
- ③ Head plate
- ④ Screw
- ⑤ Cover
- ⑥ Cover plate
- ⑦ Valve plate
- ⑧ Sealing ring
- ⑨ Structured diaphragm
- ⑩ Diaphragm support
- ⑪ Diaphragm spacer(s)
- ⑬ Connecting rod
- ⑭ Eccentric
- ⑯ Counter weight

phone number).

### 5.1.2 N 811 K\_18

#### Parts/tools required:

- Service Set (see section 8)
- Philips-head screwdriver No. 1
- Small screwdriver
- Pencil

Changing the structured diaphragm, valve plates, and sealing rings in the following sequence:

- a) Remove pump head
- b) Change structured diaphragm
- c) Change valve plates and sealing rings
- d) Refit pump head

See figs. 6 and 7.

#### a) Removing pump head

- ① Mark the position of head plate ③, intermediate plate ②, cover ⑤ and cover plate ⑥ relative to each other by a drawing line with a pencil. This helps avoid incorrect assembly later.
- ② Undo the 4 screws ④ in the head plate ③ and lift the head plate together with intermediate plate ② off the pump housing.

#### b) Change structured diaphragm

- ① Using a small screwdriver, between the housing ① and the outer edge of the structured diaphragm ⑨, carefully lever the edge of the diaphragm lightly upwards.
- ② Grip the structured diaphragm ⑨ on opposite sides, unscrew it about two turns (anti-clockwise).
- ③ Hold the pump with one hand, so that the head is pointing downwards. Turn the structured diaphragm ⑨ anti-clockwise to unscrew it.
- ④ Take the diaphragm support ⑩ and diaphragm spacer(s) ⑪ off the threaded portion of the structured diaphragm ⑨ and retain them.
- ⑤ Check that all parts are free from dirt and clean them if necessary (see section 6. *Cleaning*).
- ⑥ Put the diaphragm support ⑩, and diaphragm spacer(s) ⑪ in that order, on the threaded portion of the new structured diaphragm ⑨.
- ⑦ Screw the new structured diaphragm ⑨, complete with diaphragm support ⑩ and diaphragm spacer(s) ⑪ into the connecting rod (clockwise) and tighten it by hand.

#### c) Changing the valve plates

- ① Remove the valve plates ⑦ and sealing rings ⑧ from the intermediate plate ② (sealing rings could cling to the head plate).
- ② Check that the valve seats in the head plate ③ and intermediate plate ② are clean. If scratches or

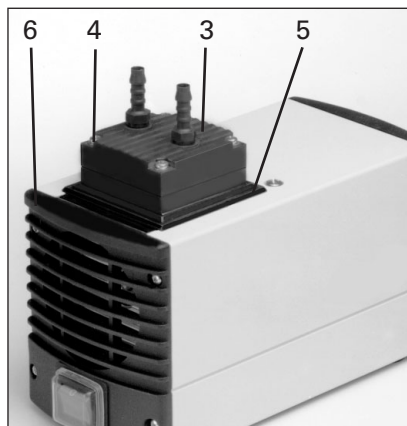

Fig. 6: N 811 K\_18

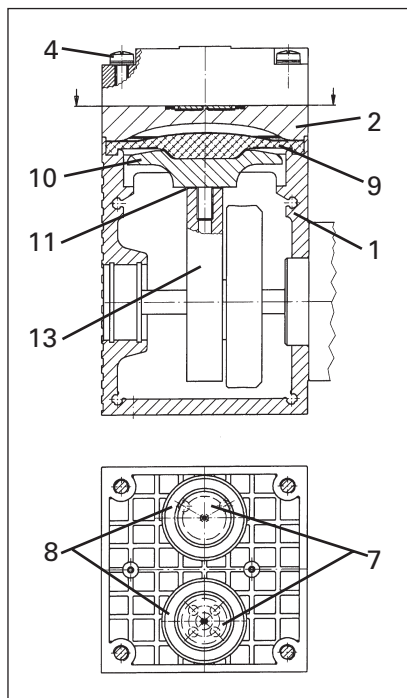

Fig. 7: N 811 K\_18

#### Specification

- ① Housing
- ② Intermediate plate
- ③ Head plate
- ④ Screw
- ⑤ Cover
- ⑥ Cover plate
- ⑦ Valve plate
- ⑧ Sealing ring
- ⑨ Structured diaphragm
- ⑩ Diaphragm support
- ⑪ Diaphragm spacer(s)
- ⑬ Connecting rod
- ⑬ Counter weight

distortion are evident on these parts they should be replaced.

- ③ Lay the new valve plates ⑦ in the recesses in the intermediate plate ②. The valve plates for suction and pressure sides are identical, as are upper and lower sides of the

plates.

- ④ Check that the valve plates ⑦ are not deformed by moving them gently sideways in their recesses.
- ⑤ Lay the new sealing rings on the intermediate plate.

#### d) Refitting the pump head

- ① Place the intermediate plate ②, with valve plates ⑦ and sealing rings ⑧ on the housing ①, in the position indicated by the drawing line.
- ② Place the head plate ③, with cover ⑤ on the housing ①, in the position indicated by the drawing line.
- ③ Check that the head plate ③ is centred by moving it gently sideways.
- ④ Tighten the screws ④, evenly and diagonally, first gently, then firmly.

► If you have any questions about servicing call our technical adviser (see last page for contact telephone number).

### 5.1.3 N 816 K\_18

#### Parts and tools required

- Service Set (see section 8)
- Phillips screwdriver no. 2
- Small screwdriver (blade width 0.5 mm)
- Pencil

Change the structured diaphragms, valve plates, and sealing rings in the following sequence:

- a) Remove pump heads
- b) Change structured diaphragms
- c) Change valve plates and sealing rings
- d) Refit pump heads

Proceed as follows (see figs. 8, 9 and 10):

#### a) Remove pump heads

- ① At both pump heads: Mark the position of head plate ④, intermediate plate ①, cover ⑬ and housing ⑭ relative to each other by a drawing line (M) with a pencil. This helps avoid incorrect assembly later.
- ② At both pump heads: Undo the 4 screws ⑤ in the head plate ④.
- ③ Remove both pump heads (each consisting of a head plate ④ and intermediate plate ①) together from the pump housing ⑭.

#### b) Change structured diaphragms

(for each pump head separately)

- ① Push down one structured diaphragm ⑩ to bring the other structured diaphragm ⑩ to top dead

centre.

- 2 Lift the edge of the highest structure diaphragm 11 and, gripping it on opposite sides, unscrew it by turning anti-clockwise.
  - ▶ Make sure the diaphragm spacers 12 on the thread of the structured diaphragm 11 do not fall into the pump housing.
- 3 Take the diaphragm spacers 12 off the threaded portion of the structured diaphragm 11 and retain them.
- 4 Check that all parts are free from dirt and clean them if necessary (see section 6. *Cleaning*).
- 5 Put the diaphragm spacers 12 on the thread of the new structured diaphragm 11.
- 6 Push down the structured diaphragm 11 of the second pump head until the connecting rod (connecting part between motor shaft and structured diaphragm) is at top dead centre.
- 7 Screw the new structured diaphragm 11, complete with diaphragm spacers 12, into the connecting rod (clockwise) and tighten it by hand.
- 8 Carry out steps 1 to 7 for the second pump head.

### c) Change valve plates and sealing rings

(for each pump head separately)

- 1 Only for pumps N 816.3 KN.18 and N 816.3 KT.18: Pull the connecting tube 10 out of one of the two head plates 4; take care to ensure that the sealing 8 and the O-ring 9 are not lost.
- 2 For one pump head: Use a small screwdriver to undo the two screw caps 6 on the pump head and then undo the screws 7.
- 3 Separate the head plate 4 from intermediate plate 1.
- 4 Remove the valve plates 2 and sealing rings 3 from the intermediate plate 1.
- 5 Check that the valve seats in the head plate 4 and intermediate plate 1 are clean; if scratches or distortion are evident on these parts they should be replaced.
- 6 Lay the new valve plates 2 in the recesses in the intermediate plate 1. The valve plates for suction and pressure sides are identical, as are upper and lower sides of the plates.
- 7 Check that the valve plates 2 are not deformed by moving them gently sideways in their recesses.
- 8 Lay the new sealing rings 3 in the intermediate plate 1.
- 9 Place the head plate 4 on the intermediate plate 1, in the position indicated by the marking (M).
- 10 Check that the head plate 4 is centred by moving it gently sideways.

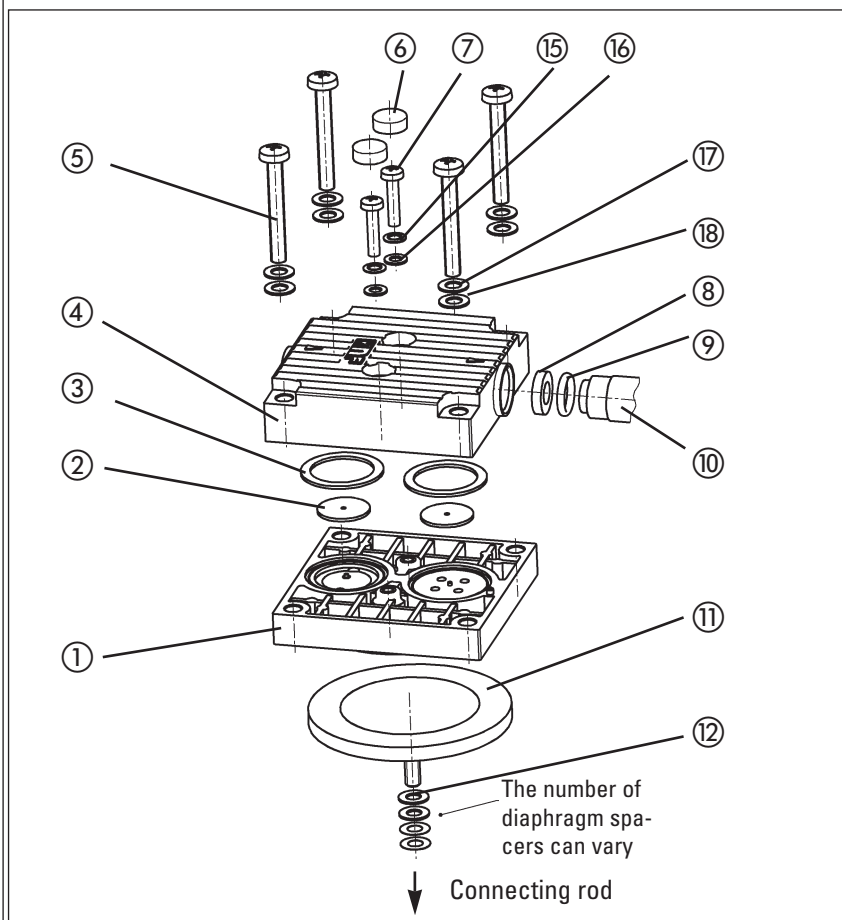

Fig. 8: Pump head N 816.1.2 K\_.18 (exploded drawing)

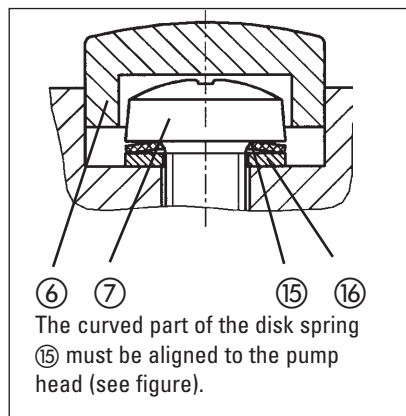

Fig. 9: Orientation of disk spring 15

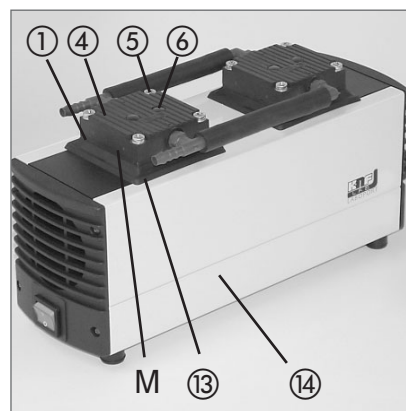

Fig. 10: N 816.1.2 KN.18

### Specification

Pos. Description

- 1 Intermediate plate
- 2 Valve plate
- 3 Sealing ring
- 4 Head plate
- 5 Screw
- 6 Screw cap
- 7 Screw
- 8 Sealing\*
- 9 O-ring\*
- 10 Connecting tube\*
- 11 Structured diaphragm
- 12 Diaphragm spacer
- 13 Cover
- 14 Housing
- 15 Disk spring
- 16 Washer
- 17 Spring Washer
- 18 Washer

M: Mark

\* only for N 816.3 KN.18 and N 816.3 KT.18

- 11 Join the head plate ④ and the intermediate plate ①:  
Tighten the two screws ⑦ (tightening torque: 70 Ncm)
  - ▶ For placement of disk spring ⑮ and washer ⑯ and for orientation of disk spring see fig. 9.
- 12 Install the screw caps ⑥.
- 13 Carry out steps ② to ⑫ for the second pump head.

#### d) Refit pump heads

- 1 Only for pumps N 816.3 KN.18 and N 816.3 KT.18: Put the sealing ⑧ into the head plate ④; push the connecting tube ⑩ into the hole in the head plate ④.
    - ▶ It is necessary to ensure that the O-ring ⑨ lies on the end of the connecting tube.
  - 2 Place the two pump heads that are joined by the pneumatic connecting tube(s) ⑩ on the housing according to the markings (M).
    - ▶ Make sure the cover ⑬ is placed on the pump head and is not jammed. For this, carefully slide a small screw driver between the cover ⑬ and the pump head.
    - ▶ If the cover is jammed between the intermediate plate ① and head plate ④, then the pump will not provide the nominal pneumatic performance.
  - 3 On both pump heads: Gently tighten the screws ⑤, evenly and diagonally (tightening torque: 3 Nm).
    - ▶ The spring washer ⑰ and washer ⑱ under the screws ⑤ are placed and aligned like the disk spring and washer at the screw ⑦ (see fig. 9).
- ▶ If you have any questions about servicing call our technical adviser (see last page for contact telephone number).

#### 6. Cleaning

- When changing structured diaphragm(s) and valve plates, inspect all parts for dirt before assembling the pump head and clean them if necessary.
- As far as possible, clean the parts with a dry cloth. Only use solvents for cleaning if the head materials cannot be attacked (check the resistance of the material!).

#### 7. Trouble Shooting

- ⚠ **Before working on the pump isolate the power supply securely, then check that the lines are not live.**
- ▶ The following tips for fault-finding are best employed in the sequence shown.

#### Pump produces no flow

- Thermal switch has opened due to over-heating.
  - ▶ Disconnect pump from mains and allow to cool. Trace cause of over-heating and eliminate it.
- Fuses in the pump are defective (only authorized/qualified personnel should investigate this problem)
  - ▶ Remove the pump from the source of electrical power by pulling the power plug.
  - ▶ At the pump housing, fuses are located at the IEC plug (except for pump types N 816.\_K\_.18: fuses are located in the housing, and can be accessed by removing the fan cover).
  - ▶ Fuse ratings: see Table 1.
  - ▶ Order numbers for fuses: see Chapter 8.
- Connections or lines are blocked.
- An external valve is closed, or a filter blocked.
- Liquid (condensate) has collected in the pump head.
  - ▶ Let the pump run for a few minutes pumping air.
  - ▶ Install the pump at the highest point in the system.
- Diaphragm or valve plates are worn.
  - ▶ Section 5 *Servicing*.

#### Flow, pressure, or vacuum too low

- Compare the actual performance with the figures in table 2 or the data sheet.
- There is pressure on the pressure side, and at the same time vacuum, or a pressure above atmospheric, on the suction side.
  - ▶ The pump is not designed for this condition.
- Liquid (condensate) has collected in the pump head.
  - ▶ Let the pump run for a few minutes pumping air.
  - ▶ Install the pump at the highest point in the system.
- The cross-section of pneumatic lines, or connected components is too small, or they are restricted.
  - ▶ To measure the performance, disconnect the pump from the system (small diameter tubing or a valve can significantly affect performance).
- There is a leak at a connector, in a line, or in the pump head.
- Diaphragm or valve plates are worn, or dirt is in the head.
  - ▶ Section 5 *Servicing*.
- ▶ If the pump does not operate properly and you cannot find any of the above faults, send it to the KNF Service Department.
  - ▶ In order for KNF to repair the pump, the customer must provide a statement on the media which

were pumped and on pump cleaning. Please fill out the corresponding KNF form, and submit it together with the pump. A sample statement for copying can be found in the Appendix of these operating instructions.

#### 8. Replacement Parts

A Service Set contains all replacement parts needed for one complete service. For one-headed pumps: 1 structured diaphragm, 2 valve plates and 2 sealing rings; for two-headed pumps: 2 structured diaphragms, 4 valve plates and 4 sealing rings.

for Pump type:	Order-No.:
N 86 KN.18	043241
N 86 KT.18	043242
N 811 KN.18	044066
N 811 KT.18	044067
N 816.1.2 KN.18	056315
N 816.1.2 KT.18	056316
N 816.3 KN.18	056315
N 816.3 KT.18	056316

#### Fuses

There are two fuses for each pump.

Pump range	Order-No. fuse (1 piece)
N 86 K_.18, 230 V	025250
N 86 K_.18, 115 V	029986
N 86 K_.18, 100 V	020085
N 811 K_.18, 230 V	025250
N 811 K_.18, 115 V	029986
N 811 K_.18, 100 V	020085
N 816._K_.18, 230 V	025250
N 816._K_.18, 115 V	027576
N 816._K_.18, 100 V	027575

#### 9. Accessories

##### N 86 K\_.18

Description:	Order-No.:
Silencer	000345
Filter	000346
Hose connector PVDF	025671

##### N 811 KN.18

Description:	Order-No.:
Silencer/Filter	000346

##### N 811 KT.18

Description:	Order-No.:
Silencer/Filter	000346
Hose connector PVDF	014052

#### 10. Tables

See next page.

**Table 1: Electrical Data****N 86 K\_18****Electrical Type**

<b>Voltage</b>	230 V	100 V	115 V
<b>Frequency</b>	50 Hz	50/60 Hz	60 Hz
<b>Power consumption</b>	65 W	70 W	60 W
<b>Operating current</b>	0.63 A	1.8 A	1.2 A
<b>Fuse* (2 x) T (A)</b>	1.0	3.5	3.2

\*Order-No. see section 8

**N 811 K\_18****Electrical Type**

<b>Voltage</b>	230 V	100 V	115 V
<b>Frequency</b>	50 Hz	50/60 Hz	60 Hz
<b>Power consumption</b>	65 W	70 W	75 W
<b>Operating current</b>	0.8 A	1.5 A	1.3 A
<b>Fuse* (2 x) T (A)</b>	1.0	3.5	3.2

\*Order-No. see section 8

**N 816\_ K\_18****Electrical Type**

<b>Voltage</b>	230 V	100 V	115 V
<b>Frequency</b>	50 Hz	50/60 Hz	60 Hz
<b>Power consumption</b>	100 W	100 W	100 W
<b>Operating current</b>	0.6 A	1.2 A	0.9 A
<b>Fuse* (2x) T (A)</b>	1.0	2.5	2.5

\*Order-No. see section 8

**Table 2: Pneumatic Data**

<b>Pump type</b>	<b>Delivery (l/min*)</b>	<b>Ultimate vacuum (mbar abs)</b>	<b>Maximum permissible operating pressure (bar g)</b>
N 86 KN.18	6	100	2.4
N 86 KT. 18	5.5	160	2.5
N 811 KN.18	11.5	240	2
N 811 KT.18	11.5	290	2
N 816.1.2 KN.18	30	100	0.5
N 816.1.2 KT.18	30	160	0.5
N 816.3 KN.18	16	15	0.5
N 816.3 KT.18	16	20	0.5

\* Litre at STP at atm. pressure

**Table 3: Pump Materials**

<b>Pump Type</b>	<b>Material</b>		
	<b>Pump head</b>	<b>Structured diaphragm</b>	<b>Valves</b>
N 86 KN.18	PPS	EPDM	FPM
N 86 KT.18	PPS	PTFE-coated	FFPM
N 811 KN.18	PPS	EPDM	FPM
N 811 KT.18	PPS	PTFE-coated	FFPM
N 816.1.2 KN.18	PPS	EPDM	EPDM
N 816.1.2 KT.18	PPS	PTFE	FFPM
N 816.3 KN.18	PPS	EPDM	EPDM
N 816.3 KT.18	PPS	PTFE	FFPM

Material abbreviations according to DIN ISO 1629 and 1043.1

**KNF Neuberger GmbH,  
Alter Weg 3,  
D-79112 Freiburg**

**Telephone ++49/7664/5909-0  
Telefax ++49/7664/5909-99  
E-mail: info@knf.de  
www.knf.de**

**Appendix:  
Customer statement for  
repair order (sample  
statement for copying)**

- ▶ In order for KNF to repair the pump, the customer must provide a statement on the media which were pumped and on pump cleaning. Please fill out the corresponding KNF form, and submit it together with the pump.

**Statement/Certificate**

We confirm that the pump model listed below (please specify)

.....  
.....

Serial-No. (please specify)

.....  
.....

was used to pump the following media:

.....  
.....  
.....  
.....  
.....  
.....

and that the pump listed above was cleaned. There are no poisonous, aggressive, biological, radioactive or other media in the pump.

.....  
Company

.....  
Date/  
Signature

**KNF Neuberger GmbH,  
Alter Weg 3,  
D-79112 Freiburg**

**Telephone ++49/7664/5909-0  
Telefax ++49/7664/5909-99  
E-mail: info@knf.de  
www.knf.de**